



PAPION SECURITY BOLLARD

CODE:ART27-KK-FF-BB-QQ-RR-AA

CODE:

ART 27

GENERAL CHARACTERISTICS:

Voltage:	110-277V
Source Type:	LED
Wattage:	20W
Operating Temperature:	-22°F~122°
IP Rating:	IP 65
CRI:	80
FLUX:	1800lm
Dimmable:	0-10V

BOLLARD COVER MATERIAL:

Stainless steel+Acrylic

DIMENSIONS:

Height (KK): 47"/48"/48"/50"/52"/ CUS*

Diameter (FF): 8"/9"/10"(choose depending on a security rating needed*)

LENS TYPE (BB):

20	Standard Clear Lens
21	Frosted acrylic lens

FINISHES(QQ):

11	316 Stainless steel with a #4 swirl brushed stainless surface finish
12	Custom RAL

Stainless powder coated standard colors:

30.	Black
33.	White
36.	Dark Grey
40.	Light Grey

SECURITY RATING(RR): Please Read our Security Bollards Guide below

BDS-C40FB36-ST	ASTM SC40 CRASH RATED FIXED BOLLARD
BDS-M30-FB-ST	ASTM M30 CRASH RATED FIXED BOLLARD
BDS-M30FB-SH	ASTM M30 CRASH RATED SHALLOW BOLLARD
BDS-PU40FB36-ST	ASTM PU40 CRASH RATED FIXED BOLLARD
BDS-H40FB-ST	ASTM H40 CRASH RATED FIXED BOLLARD
BDS-H30FB-ST	ASTM H30 CRASH RATED FIXED BOLLARD

COLOUR TEMPERATURE (AA):

01.	3000K
02.	4000K

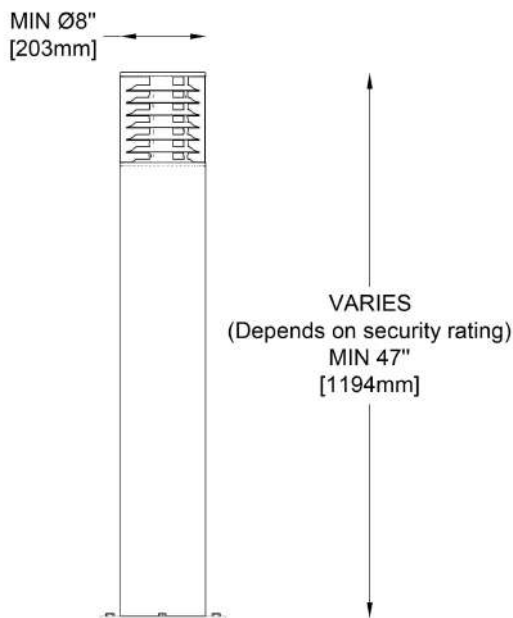

sales@gordonbullard.com
www.bullardbollards.com
1-877-964-4646



991 South Gull Lake Dr
Richland, MI 49083
USA

Vehicle Speed:

ASTM CRASH RATINGS

(M) Medium-duty truck (15,000 lbs)

- M30 (30 mph)
- M40 (40 mph)
- M50 (50 mph)

(C) Small passenger car (2,430 lbs)

- C40 (40 mph)
- C50 (50 mph)
- C60 (60 mph)

(PU) Pickup truck (5,070 lbs)

- PU40 (40 mph)
- PU50 (50 mph)
- PU60 (60 mph)

(H) Heavy goods vehicle (65,000 lbs)

- H30(30mph)
- H40(40mph)
- H50(50 mph)

Penetration ratings for high-speed standards are as follows and apply to all vehicle sizes.

P1: Less than 3.3 feet

P2: 3.31 to 23.0 feet

P3: 23.1 to 98.4 feet

STYLE VARIATIONS AMONG BOLLARDS:

PASSIVE UPRIGHT MOUNT—FIXED

- A permanent solution to preventing unauthorized vehicular access
- Pier-Type Footing (or Continuing Grade Beam Footing)

PASSIVE UPRIGHT MOUNT—REMOVABLE

- Internal or external locking systems
- Physical removal required
- High-security versions, because of greater weight (300-1200 lbs.) will require heavy lifting equipment
- No locking mechanism is required due to the sheer weight of the bollard

PASSIVE SHALLOW MOUNT BOLLARD

- Prefabricated in the factory to meet specific site requirements
- Site specifications are ready to accept prefabricated single-to-multiple bollard units upon delivery by heavy-duty truck
- Unique in the industry by allowing location over undisturbed utility—electrical, plumbing, communications‐ equipment that otherwise would be damaged by a deep-set vertical fixed or removable bollard

PASSIVE SURFACE MOUNT

- This system is the newest addition to the bollard family and comes in M30 and M50 capacities
- Its value is in its potential rapid random placement, although not yet shown as relevant to a RAM exercise (discussed below) because of size and weight. It can be deployed/removed/redeployed using heavy equipment and configured to local site configurations.

NOTE*:

Penetration indicates the test vehicle's maximum dynamic distance of penetration after impact with the barrier. Typically, the dynamic distance is barrier face to the front of the cargo bed. The barrier penetration rating does not imply that a barrier will perform as rated in all site conditions, approach routes, and topography. Also, only single-specimen tests at a specified impact location are required by this test method, and therefore, not all points of impact can be tested and validated for the penetration rating. Other impact locations may respond differently.

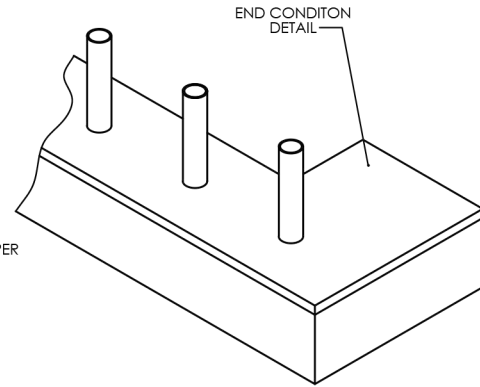
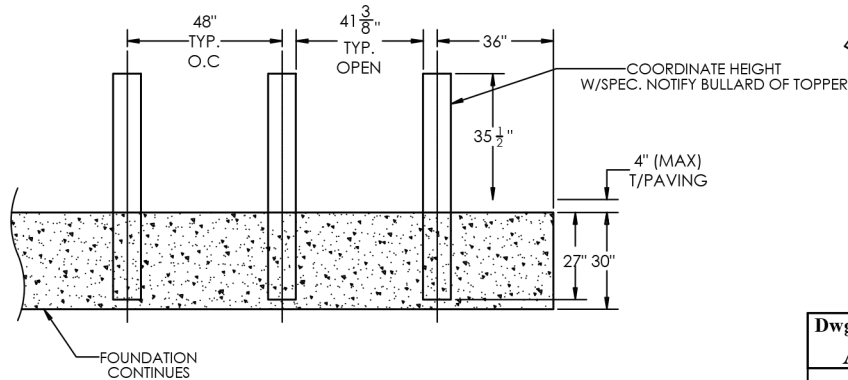
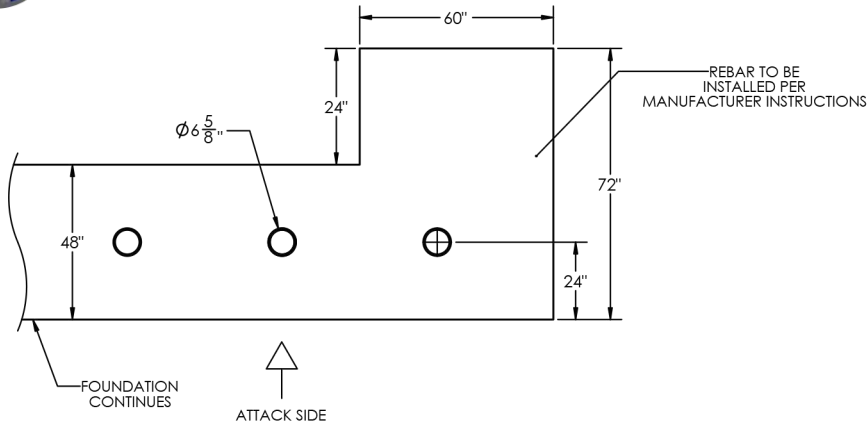

Dwg Title: ASTM C40	Created by: Bullard Bollards	Size: A4	Version: 1
 BULLARD BOLLARDS		Current date: 29.04.2020	
		Added: 29.04.2020	
		Scale: 1:1	Sheet: 1/1

1.Foundation Requirements:

- a.Depth: 30 inches (762 mm).
- b.Concrete: 4500 psi (31026.4 kPa) concrete.
- c.Rebar: No. 5 bar.

2.Compliance:

- a.ASTM F2656: C40 P1, 2430 lbs (1102.2 kg) at 40 mph (64.4 kph), less than 39.37 inch (1.0 m) penetration.
- b.Welding: Conforms with AWS D1.1 standard.

3.Bollard Height Above Finished Grade: 30 inches (762 mm) or 36 inches (914 mm); pavers or other concrete topper is acceptable up to an additional 4 inches (102 mm). Notify manufacturer of requirement in advance prior to fabrication.

4.Maximum Bollard Spacing: 48 inches (1219 mm) on center; meeting ADA handicap accessibility provision after decorative covers are installed.

**** NOTE TO SPECIFIER **** A minimum of a 3 bollard array is required. If a smaller array is desired, engineering review and approval is required from manufacturer in order to validate prescribed crash rating. To be installed in areas where underground interferences are not a concern. Typically installed into sidewalks, roadways or other areas requiring perimeter defense where there is NOT a removable bollard requirement. Bollard height above finished grade shall remain at 39 inches (991 mm) unless otherwise approved via written consent from the manufacturer.

sales@gordonbullard.com
www.bullardbollards.com
1-877-964-4646



991 South Gull Lake Dr
Richland, MI 49083
USA

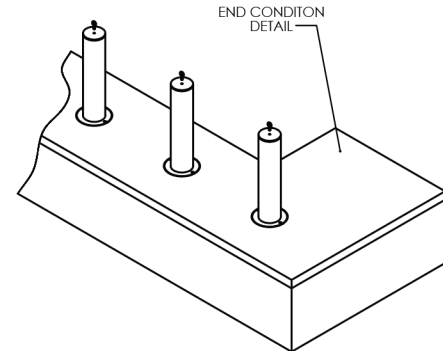
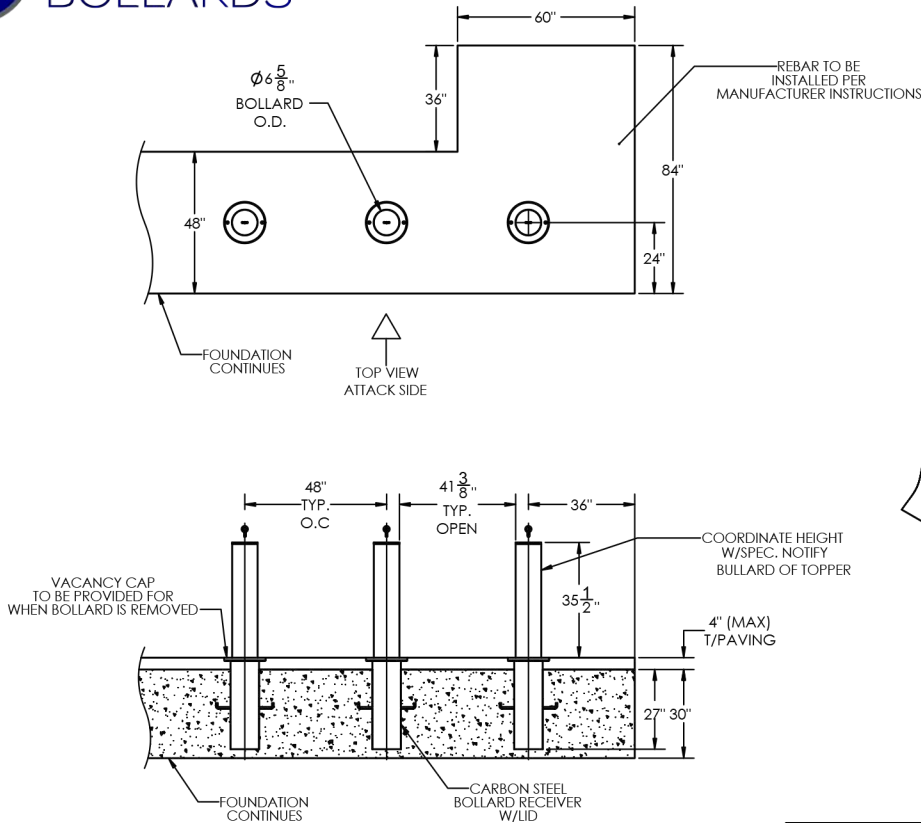

Dwg Title: ASTM C40	Created by: Bullard Bollards	Size: A4	Version: 1
 BULLARD BOLLARDS		Current date: 29.04.2020	
		Added: 29.04.2020	
		Scale: 1:1	Sheet: 1/1

1.Foundation Requirements:

- a.Depth: 30 inches (762 mm).
- b.Concrete: 4500 psi (31026.4 kPa) concrete.
- c.Rebar: No. 5 bar.

2.Compliance:

- a.ASTM F2656: C40 P1, 2430 lbs (1102.2 kg) at 40 mph (64.4 kph), less than 39.37 inch (1.0 m) penetration.
- b.Welding: Conforms with AWS D1.1 standard.

3.Bollard Height Above Finished Grade: 30 inches (762 mm) or 36 inches (914 mm); pavers or other concrete topper is acceptable up to an additional 4 inches (102 mm). Notify manufacturer of requirement in advance prior to fabrication.

4.Maximum Bollard Spacing: 48 inches (1219 mm) on center; meeting ADA handicap accessibility provision after decorative covers are installed.

**** NOTE TO SPECIFIER **** A minimum of a 3 bollard array is required. If a smaller array is desired, engineering review and approval is required from manufacturer in order to validate prescribed crash rating. To be installed in areas where underground interferences are not a concern. Typically installed into sidewalks, roadways or other areas requiring perimeter defense where there IS a removable bollard requirement. Bollard height above finished grade shall remain at 30 inches (762 mm) unless otherwise approved via written consent from the manufacturer.

sales@gordonbullard.com

www.bullardbollards.com

1-877-964-4646



991 South Gull Lake Dr

Richland, MI 49083

USA



BULLARD BOLLARDS

ASTM M30 CRASH RATED FIXED BOLLARD GENERAL ARRANGEMENT

ORDERING CODE: BDS-M30-FB-ST

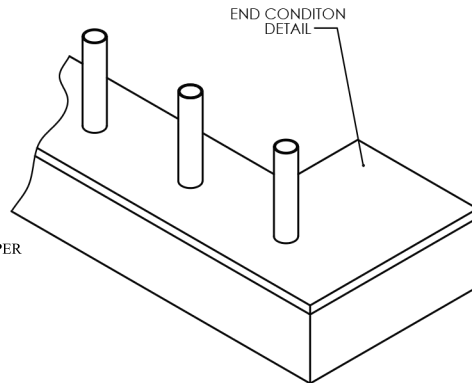
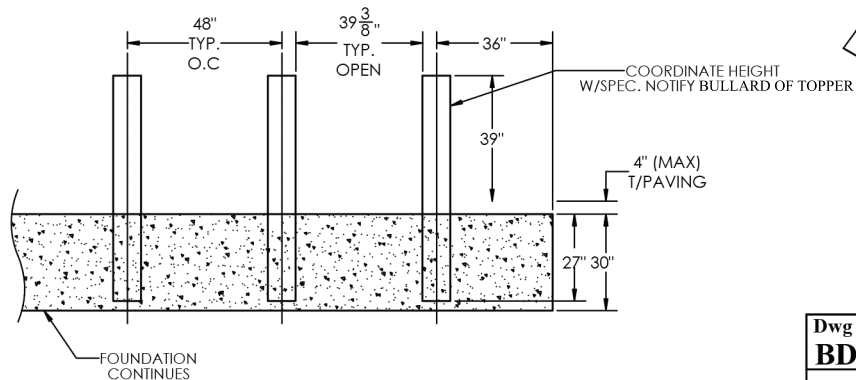
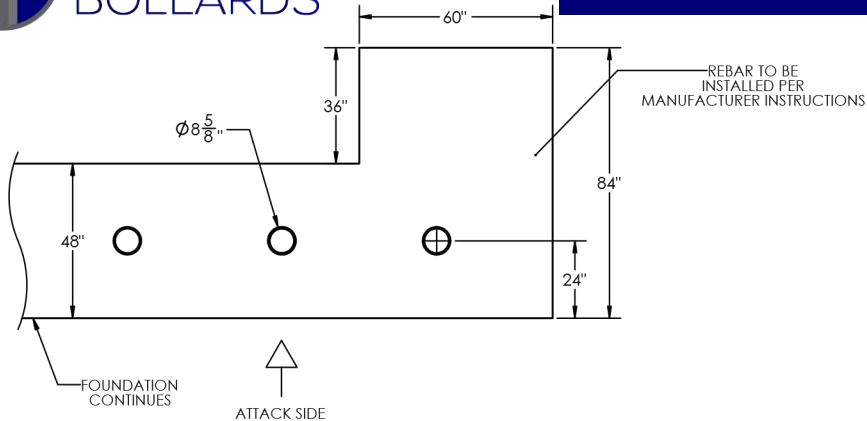

Dwg Title: BDS-M30FB-ST	Created by: Bullard Bollards	Size: A4	Version: 1
 BULLARD BOLLARDS		Current date: 29.04.2020	
		Added: 29.04.2020	
		Scale: 1:1	Sheet: 1/1

1. Foundation Requirements:

- a. Depth: 30 inches (762 mm).
- b. Concrete: 4500 psi (31026.4 kPa) concrete.
- c. Rebar: No. 5 bar.

2. Compliance:

- a. ASTM F2656: M30 P1, 15000 lbs (6804 kg) at 30 mph (48.3 kph), less than 39.37 inch (1.0 m) penetration.
- b. Welding: Conforms with AWS D1.1 standard.

3. Bollard Height Above Finished Grade: 39 inches (991 mm); pavers or other concrete topper is acceptable up to an additional 4 inches (102 mm). Notify manufacturer of requirement in advance prior to fabrication.

4. Maximum Bollard Spacing: 48 inches (1219 mm) on center; meeting ADA handicap accessibility provision after decorative covers are installed.

**** NOTE TO SPECIFIER **** A minimum of a 3 bollard array is required. If a smaller array is desired, engineering review and approval is required from manufacturer in order to validate prescribed crash rating. To be installed in areas where underground interferences are not a concern. Typically installed into sidewalks, roadways or other areas requiring perimeter defense where there is NOT a removable bollard requirement. Bollard height above finished grade shall remain at 39 inches (991 mm) unless otherwise approved via written consent from the manufacturer.

sales@gordonbullard.com
www.bullardbollards.com
1-877-964-4646



991 South Gull Lake Dr
Richland, MI 49083
USA

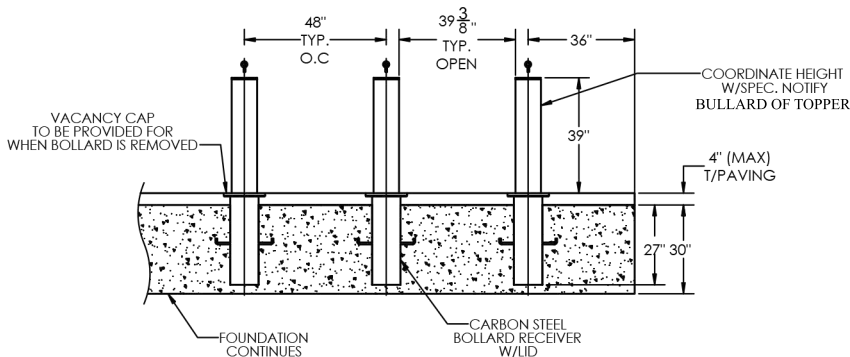
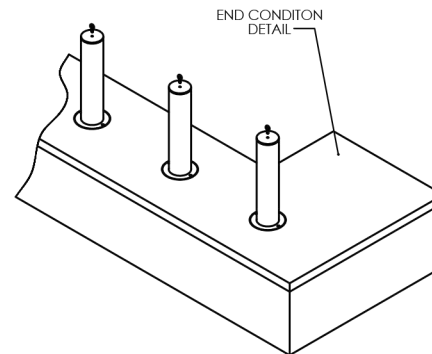
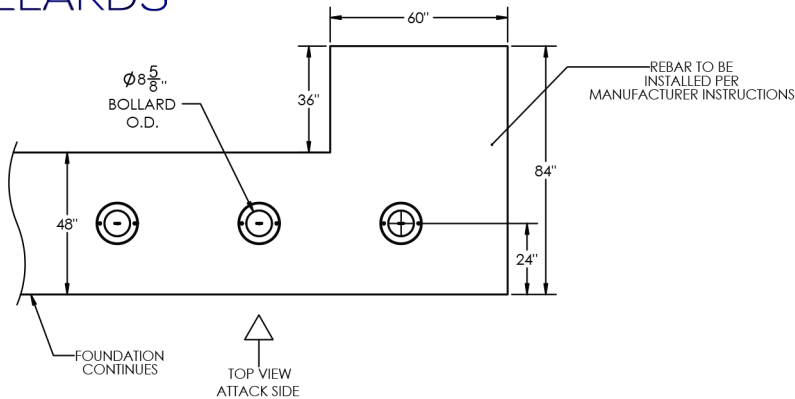

Dwg Title: ASTM M30	Created by: Bullard Bollards	Size: A4	Version: 1
 BULLARD BOLLARDS		Current date: 29.04.2020	
		Added: 29.04.2020	
		Scale: 1:1	Sheet: 1/1

1.Foundation Requirements:

- a.Depth: 30 inches (762 mm).
- b.Concrete: 4500 psi (31026.4 kPa) concrete.
- c.Rebar: No. 5 bar.

2.Compliance:

- a.ASTM F2656: M30 P1, 15000 lbs (6804 kg) at 30 mph (48.3 kph), less than 39.37 inch (1.0 m) penetration.
- b.Welding: Conforms with AWS D1.1 standard.
- c.Bollard Height Above Finished Grade: 39 inches (991 mm); pavers or other concrete topper is acceptable up to an additional 4 inches (102 mm). Notify manufacturer of requirement in advance prior to fabrication..
- d.Maximum Bollard Spacing: 48 inches (1219 mm) on center; meeting ADA handicap accessibility provision after decorative covers are installed.

**** NOTE TO SPECIFIER **** A minimum of a 3 bollard array is required. If a smaller array is desired, engineering review and approval is required from manufacturer in order to validate prescribed crash rating. To be installed in areas where underground interferences are not a concern. Typically installed into sidewalks, roadways or other areas requiring perimeter defense where there IS a removable bollard requirement. Bollard height above finished grade shall remain at 39 inches (991 mm) unless otherwise approved via written consent from the manufacturer.

sales@gordonbullard.com
www.bullardbollards.com
1-877-964-4646



991 South Gull Lake Dr
Richland, MI 49083
USA



BULLARD BOLLARDS

ASTM M30 CRASHED RATED SHALLOW BOLLARD GENERAL ARRANGEMENT

ORDERING CODE: BDS-M30FB-SH

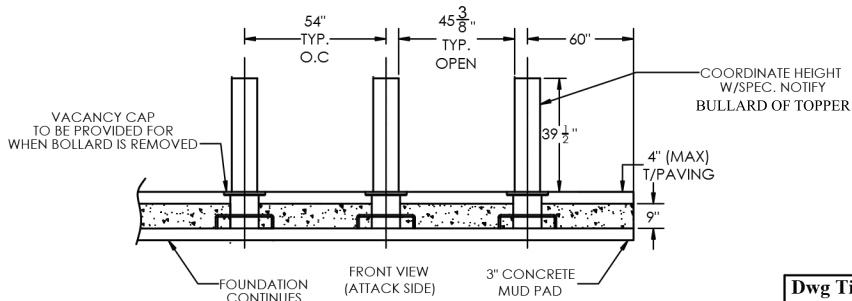
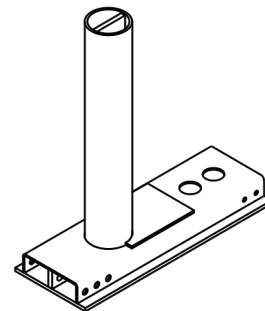
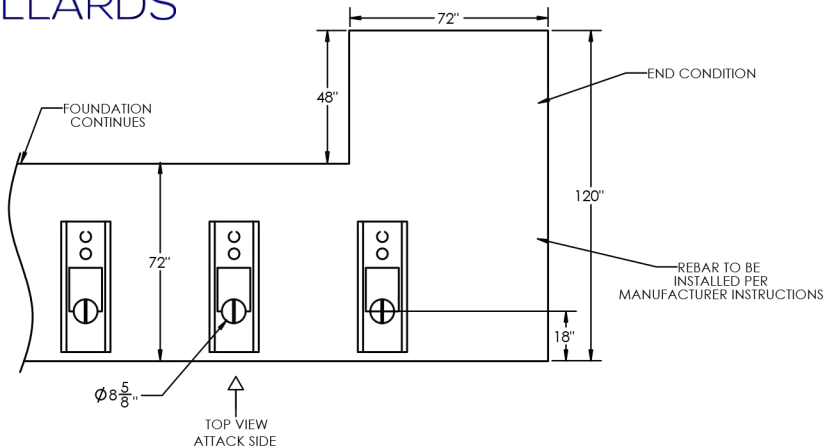

Dwg Title: BDS-M30FB	Created by: Bullard Bollards	Size: A4	Version: 1
 BULLARD BOLLARDS		Current date: 29.04.2020	
		Added: 29.04.2020	
		Scale: 1:1	Sheet: 1/1

1.Foundation Requirements:

- a.Depth: 9 inches (229 mm).
- b.Concrete: 4500 psi (31026.4 kPa) concrete.
- c.Rebar: No. 5 and No.8 bar.

2.Compliance:

- a.ASTM F2656: M30 P1, 15000 lbs (6804 kg) at 30 mph (48.3 kph), less than 39.37 inch (1.0 m) penetration.
- b.Welding: Conforms with AWS D1.1 standard.

3.Bollard Height Above Finished Grade: 39 inches (991 mm); pavers or other concrete topper is acceptable up to an additional 4 inches (102 mm). Notify manufacturer of requirement in advance prior to fabrication.

4.Maximum Bollard Spacing: 48 inches (1219 mm) on center; meeting ADA handicap accessibility provision after decorative covers are installed.

**** NOTE TO SPECIFIER **** A minimum of a 3 bollard array is required. If a smaller array is desired, engineering review and approval is required from manufacturer in order to validate prescribed crash rating. To be installed in areas where underground interferences are not a concern. Typically installed into sidewalks, roadways or other areas requiring perimeter defense where there IS a removable bollard requirement. Bollard height above finished grade shall remain at 39 inches (991 mm) unless otherwise approved via written consent from the manufacturer.

sales@gordonbullard.com

www.bullardbollards.com

1-877-964-4646



991 South Gull Lake Dr

Richland, MI 49083

USA



BULLARD BOLLARDS

ASTM M50 CRASHED RATED SHALLOW BOLLARD GENERAL ARRANGEMENT

ORDERING CODE: BDS-M50FB-SH

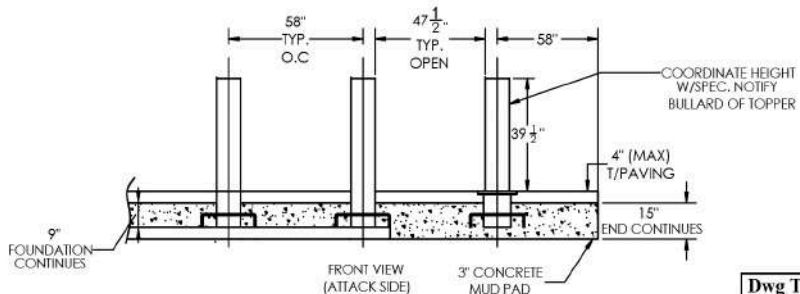
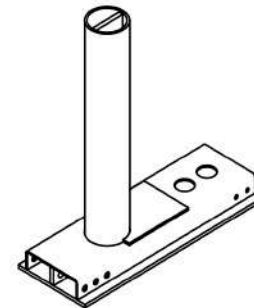
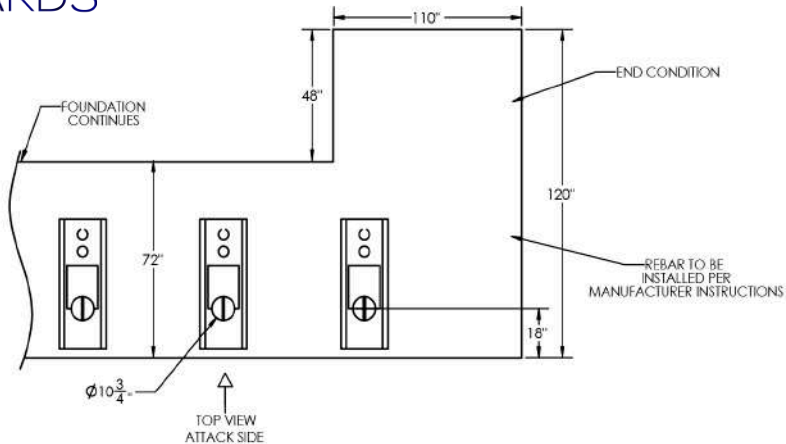

Dwg Title:	Created by:	Size:	Version:
BDS-M50FB-SH	Bullard Bollards	A4	1

Current date:
29.04.2020

Added:
29.04.2020

Scale: Sheet:
1:1 1/1



**BULLARD
BOLLARDS**

1.Foundation Requirements:

- a.Depth: 9 inches (229 mm).
- b.Concrete: 4500 psi (31026.4 kPa) concrete.
- c.Rebar: No. 5 and No.8 bar.

2.Compliance:

- a.ASTM F2656: M50 P1, 15000 lbs (6804 kg) at 50 mph (80.5 kph), less than 39.37 inch (1.0 m) penetration.
- b.Welding: Conforms with AWS D1.1 standard.

3.Bollard Height Above Finished Grade: 39.5 inches (1003 mm); pavers or other concrete topper is acceptable up to an additional 4 inches (102 mm). Notify manufacturer of requirement in advance prior to fabrication.

4.Maximum Bollard Spacing: 58 inches (1473 mm) on center; meeting ADA handicap accessibility provision after decorative covers are installed.

A minimum of a 3 bollard array is required. If a smaller array is desired, engineering review and approval is required from manufacturer in order to validate prescribed crash rating. To be installed in areas where underground interferences are not a concern. Typically installed into sidewalks, roadways or other areas requiring perimeter defense where there IS a removable bollard requirement. Bollard height above finished grade shall remain at 39 inches (991 mm) unless otherwise approved via written consent from the manufacturer.

sales@gordonbullard.com
www.bullardbollards.com
1-877-964-4646



991 South Gull Lake Dr
Richland, MI 49083
USA

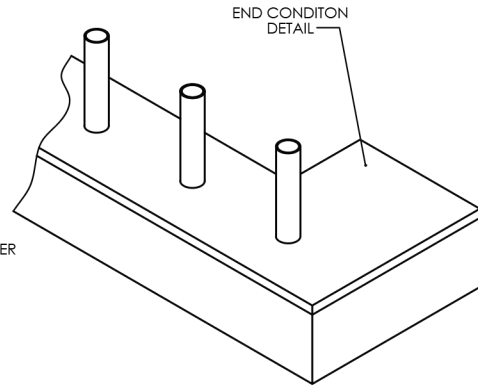
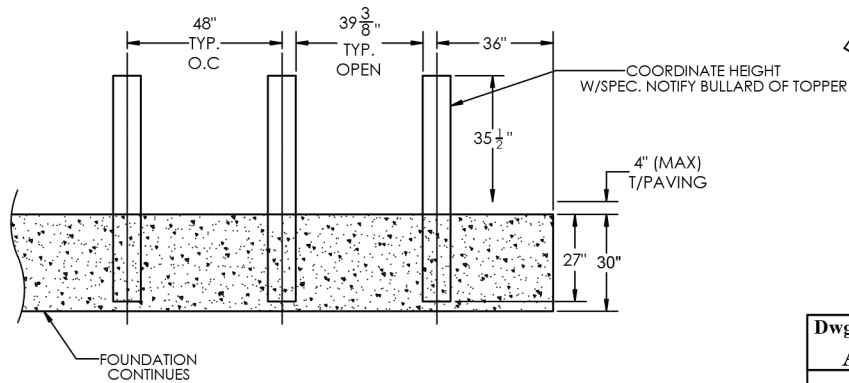
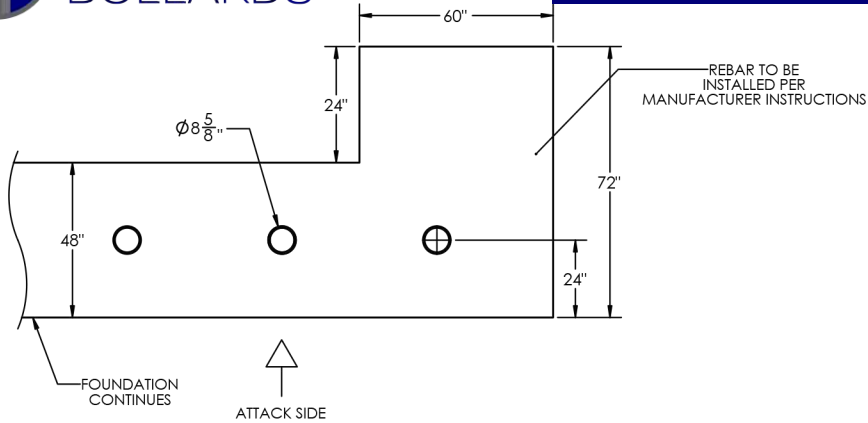

Dwg Title: ASTM PU40	Created by: Bullard Bollards	Size: A4	Version: 1
 BULLARD BOLLARDS		Current date: 29.04.2020	
		Added: 29.04.2020	
		Scale: 1:1	Sheet: 1/1

1.Foundation Requirements:

- a.Depth: 30 inches (762 mm).
- b.Concrete: 4500 psi (31026.4 kPa) concrete.
- c.Rebar: No. 5 bar.

2.Compliance:

- a.ASTM F2656: PU40 P1, 5070 lbs (2299.7 kg) at 40 mph (64.37 kph), less than 39.37 inch (1.0 m) penetration.
- b.Welding: Conforms with AWS D1.1 standard.
- c.Bollard Height Above Finished Grade: 36 inches (914 mm); pavers or other concrete topper is acceptable up to an additional 4 inches (102 mm). Notify manufacturer of requirement in advance prior to fabrication .
- d.Maximum Bollard Spacing: 48 inches (1219 mm) on center; meeting ADA handicap accessibility provision after decorative covers are installed.

**** NOTE TO SPECIFIER **** A minimum of a 3 bollard array is required. If a smaller array is desired, engineering review and approval is required from manufacturer in order to validate prescribed crash rating. To be installed in areas where underground interferences are not a concern. Typically installed into sidewalks, roadways or other areas requiring perimeter defense where there is NOT a removable bollard requirement. Bollard height above finished grade shall remain at 39 inches (991 mm) unless otherwise approved via written consent from the manufacturer.

sales@gordonbullard.com
www.bullardbollards.com
1-877-964-4646



991 South Gull Lake Dr
Richland, MI 49083
USA



**BULLARD
BOLLARDS**

ASTM PU40 CRASH RATED REMOVABLE BOLLARD GENERAL ARRANGEMENT

ORDERING CODE: BDS-PU40RB36-ST

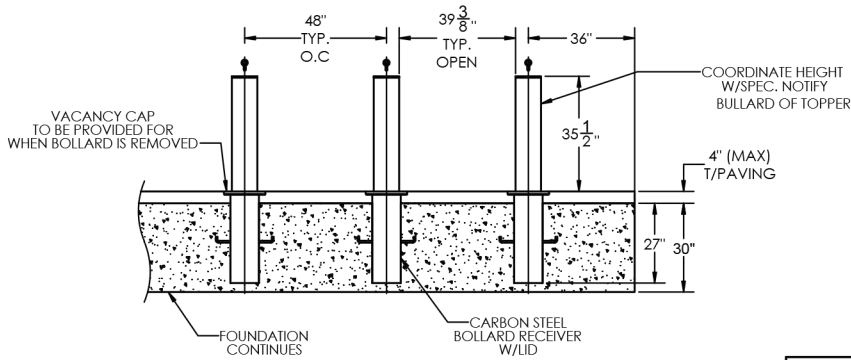
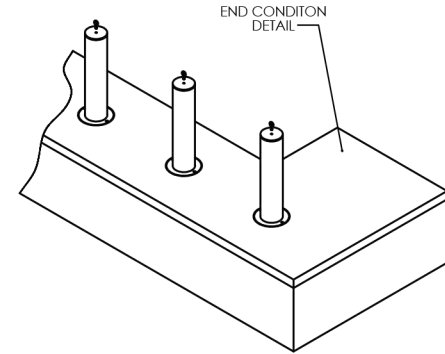
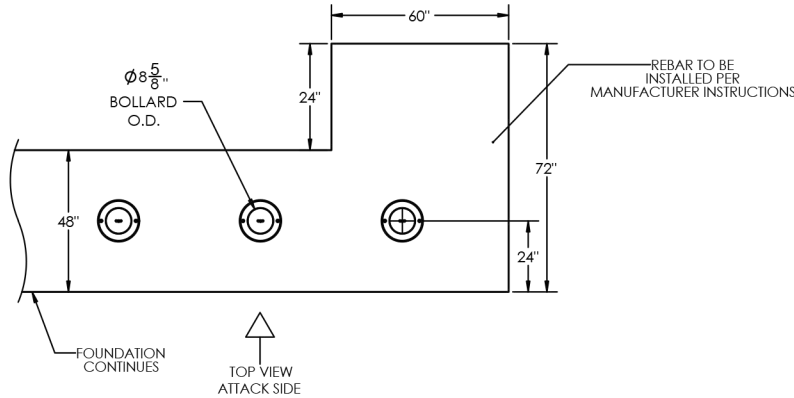

Dwg Title: ASTM PU40	Created by: Bullard Bollards	Size: A4	Version: 1
 BULLARD BOLLARDS		Current date: 29.04.2020	
		Added: 29.04.2020	
		Scale: 1:1	Sheet: 1/1

1.Foundation Requirements:

- a.Depth: 30 inches (762 mm).
- b.Concrete: 4500 psi (31026.4 kPa) concrete.
- c.Rebar: No. 5 bar.

2.Compliance:

- a.ASTM F2656: PU40 P1, 5070 lbs (2299.7 kg) at 40 mph (64.37 kph), less than 39.37 inch (1.0 m) penetration.
- b.Welding: Conforms with AWS D1.1 standard.

3.Bollard Height Above Finished Grade: 36 inches (914 mm); pavers or other concrete topper is acceptable up to an additional 4 inches (102 mm). Notify manufacturer of requirement in advance prior to fabrication.

4.Maximum Bollard Spacing: 48 inches (1219 mm) on center; meeting ADA handicap accessibility provision after decorative covers are installed.

**** NOTE TO SPECIFIER **** A minimum of a 3 bollard array is required. If a smaller array is desired, engineering review and approval is required from manufacturer in order to validate prescribed crash rating. To be installed in areas where underground interferences are not a concern. Typically installed into sidewalks, roadways or other areas requiring perimeter defense where there IS a removable bollard requirement. Bollard height above finished grade shall remain at 39 inches (991 mm) unless otherwise approved via written consent from the manufacturer.

sales@gordonbullard.com

www.bullardbollards.com

1-877-964-4646



991 South Gull Lake Dr

Richland, MI 49083

USA